

K9YA Telegraph

Robert F. Heytow Memorial Radio Club

Volume 6, Issue 11, November 2009

Amelia Earhart's Hams

Hams' Role in the Legendary Flight

Philip Cala-Lazar, K9PL

Adventure is worthwhile in itself.
Amelia Earhart (1897-1937),
pioneering aviator.

Of news stories that have attained mythic proportions few exceed Amelia Earhart's July 2, 1937 disappearance. Earhart and navigator Fred

Noonan were on a globe-circling 29,000-mile flight when they vanished somewhere near Howland Island in the Pacific Ocean.

The breadth and depth of literature and lore on Earhart's last flight is so vast a lifetime could be invested absorbing and parsing its myriad elements. So, for this article, we will merely scratch the surface by discussing the amateur radio operators most closely associated with her attempts to circumnavigate the Earth.

The aircraft she selected for this flight was a modified twin-engine Lockheed Electra 10E (NR16020) built at a cost of \$80,000. The Electra carried a mix of Western Electric and Bendix communications gear (one authority states only Bendix equipment was aboard on the second and final flight) operating with 50 watts output as KHAQQ. Earhart called this low-wing, high-performance aircraft her "flying laboratory."

The flight's operating frequencies were typical for the period: the Morse code only international calling and distress frequency at 500 kc and the aviation general communication frequencies at 3,105 kc (evening hours) and 6,210 kc (daytime hours). The receiver was an all-wave type permitting reception on other than the three transmitter frequencies.

Earhart's ability to use 500 kc was severely compromised when she ordered the Electra's 250-foot trailing antenna removed to lighten the aircraft. In an attempt to make up for the loss of the trailing antenna, the aircraft's resonant Vee antenna was lengthened rendering it non-resonant on both its fundamental and harmonic frequencies further impairing the crew's ability to communicate. Some sources claim a "tuning coil" was added at a later date to ameliorate the changes engendered by the Vee antenna's modification.

Chicago Daily Tribune

February 12, 1937: Amelia Earhart to Circle Globe East to West

The crew on this global circumnavigation included Earhart; Fred Noonan, former Pan American Airways navigator, aircraft pilot and master mariner; and Capt. Harry Manning, United States Line captain, veteran navigator, pilot and amateur radio operator.

Radio transmissions as received would be relayed to a logistical support team arranged by technical adviser (and later movie stunt pilot), Paul Mantz and Earhart's husband, George Putnam.

Amelia asked Walter McMenamy (callsign unknown), who had previously worked with Mantz, to establish

CONTINUED - AMELIA EARHART ON PAGE 6

*"Adventure is
worthwhile in itself."*



Philip Cala-Lazar, K9PL
Editor

Mike Dinelli, N9BOR
Layout

Dick Sylvan, W9CBT
Staff Cartoonist

Rod Newkirk, VA3ZBB
Contributing Editor



Robert F. Heytow
Memorial Radio Club

www.k9ya.org
telegraph@k9ya.org

Inside This Issue...

<i>Amelia Earhart's Amateur Radio...</i>	<i>Page 1</i>
<i>Direct Conversion Receivers</i>	<i>Page 2</i>
<i>The Old Man and the Paperboy</i>	<i>Page 4</i>
<i>Rod Newkirk, VA3ZBB/W9BRD</i>	<i>Page 7</i>
<i>Ham Quips</i>	<i>Page 7</i>

Direct Conversion Receivers

Part I

Paul W. Ross, W3FIS

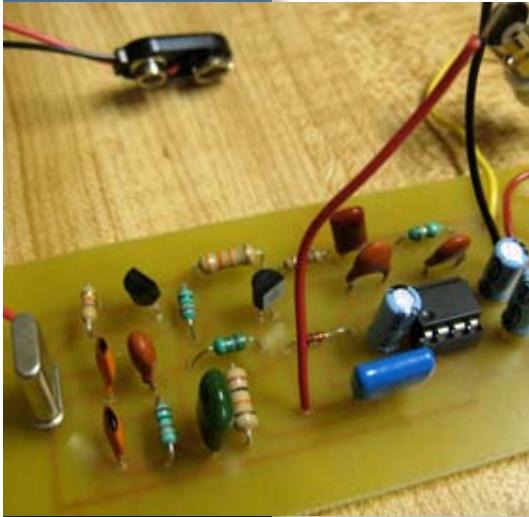

I've always been fascinated by receiver designs from the simple crystal set through multiple conversion superheterodyne systems. In previous articles, I've explored the crystal set and the regenerative receivers. I'll skip the TRF, or tuned radio frequency design, as it is really nothing more than a tuned RF amplifier (or amplifiers) in front of some sort of detector. There are classic problems with TRF stability, and getting the various stages to "track."

point, and tune for zero beat. It works, but you will quickly find the local oscillator drifts, accompanied by a serious "howl." This is a direct conversion receiver, though a primitive one.

How can we solve this problem of drift and "howl"? The answer is the "Synchrodyne" receiver. Some of the incoming carrier is captured and used, through a phase-locked loop, to stabilize the local oscillator. Oops! What was a simple idea now becomes more complex. Needless to say, the Homodyne and Synchrodyne receivers joined the boneyard of "not quite ready for prime time" ideas as superheterodyne receivers became the dominant life form with the development of pentagrid converters, which combined the local oscillator with a mixer.

All is not lost in our search for simplicity. With the advent of SSB systems in the 1950s, though the idea is really much older, we can take another look at the Homodyne detection system. Again, break out your regenerative receiver, if you have one, and tune up a SSB station in the 40- or 80-meter amateur bands. With a little "fiddling," and setting the regeneration level just into oscillation, you can nicely recover the SSB signal. Depending on whether upper or lower sideband is used, you will have to "sneak up" on the signal from either the high or low side of the signal.

*"...our search
for simplicity."*

In radio's early days attempts to simplify receiver design paralleled the development of the superheterodyne receiver. Parts, particularly vacuum tubes, were hard to come by, and expensive.

With that in mind, a number of strategies were developed.

The "Regenodyne." This was a frequency converter followed by a regenerative detector. It is always easier to build a receiver for a single, or narrow band of frequencies. This design still has a considerable amount of popularity. The usual technique is to have a crystal local oscillator with a number of switchable crystals. The output is then sent to a regenerative detector. The input circuit usually consists of a bandpass filter to reduce "image" responses. This is pretty simple—a local oscillator, a mixer, and then the regenerative detector, followed by whatever audio amplifiers are deemed necessary. The gain, usually provided by the IF strip, is picked up by the regenerative detector. This is a superheterodyne in sheep's clothing and is currently enjoying renewed popularity. The only practical problem is obtaining inexpensive crystals for the local oscillator.

The "Homodyne" receiver: In this case, a regenerative detector is run in oscillation mode. Tuning of an AM signal is done to "zero beat" the incoming signal. If you have access to a regenerative receiver, try this... just advance the regeneration control to the oscillation

Hmm. Where are we going with this? Enter the Homodyne in new attire, as the "zero IF" receiver, the darling of the CW QRP crowd. We don't need exceptional stability for such receivers if all we are trying to do is recover a CW signal. All we need to do is convert our incoming CW signal into a usable audio tone. Couldn't be simpler! Instead of an IF frequency at some lower RF value, we heterodyne to "zero IF," reducing the incoming RF signal to an audio value. Since we don't have the "carrier" of an AM signal to worry about, the "squelch" of a slightly mismatched local oscillator and incoming signal problem is no longer there.

There are a number of such direct conversion receivers on the market, ranging from amazingly simple, through some quite sophisticated designs. The simplest is the "Pixie II" transceiver. It consists of only two

Pixie II

Photo by: Michael Styne



Robert F. Heytow
Memorial Radio Club

www.k9ya.org
telegraph@k9ya.org

K9YA Telegraph

transistors and an audio amplifier chip. One transistor runs continuously as a crystal oscillator. The second transistor serves as an RF amplifier, or mixer, depending on how it is biased. The audio chip is disabled in “key down,” and otherwise amplifies the detected signal in “key up.” RF filtering and matching of the input or output is done with a simple “pi” network.

If you examine the circuit carefully, in “key up” mode, the second transistor acts as a mixer, with the resulting audio signal sent to the LM386 audio chip. In “key down,” the audio amplifier is turned off, and the second transistor now serves as a RF power amplifier. To change frequencies, all it is necessary to do is to change the crystal and the values for the input/output tank circuit.

Amazingly enough, such a simple system works, but with some problems:

- There is radiation of the continuously running oscillator through the antenna.
- The “front” end is excessively broad, so “blow-by” of local AM broadcast stations is a serious problem.
- The crystal oscillator means you receive on the same frequency you transmit on.

A more elaborate tuning circuit helps with front-end selectivity issues. The “Tiny Tornado” addresses this issue by putting a small capacitor in parallel with the pi tank inductor, resonant at the crystal frequency. This narrows up the front-end response and changes a simple low-pass filter to a band pass filter.

Putting a small (50 pF or thereabouts) switchable capacitor in series with the ground side of the crystal provides nice RIT capability. In my own Pixie II, I get about 1 kHz shift with such a value. With a fresh 9-volt battery, I get about 250 mW output into a dummy load. Selection of a different output transistor will increase the output to about 450 mW.

In the second article, I’ll discuss some more sophisticated transceiver kits that address some of these design problems in greater detail. ■



Pixie II in Cabinet

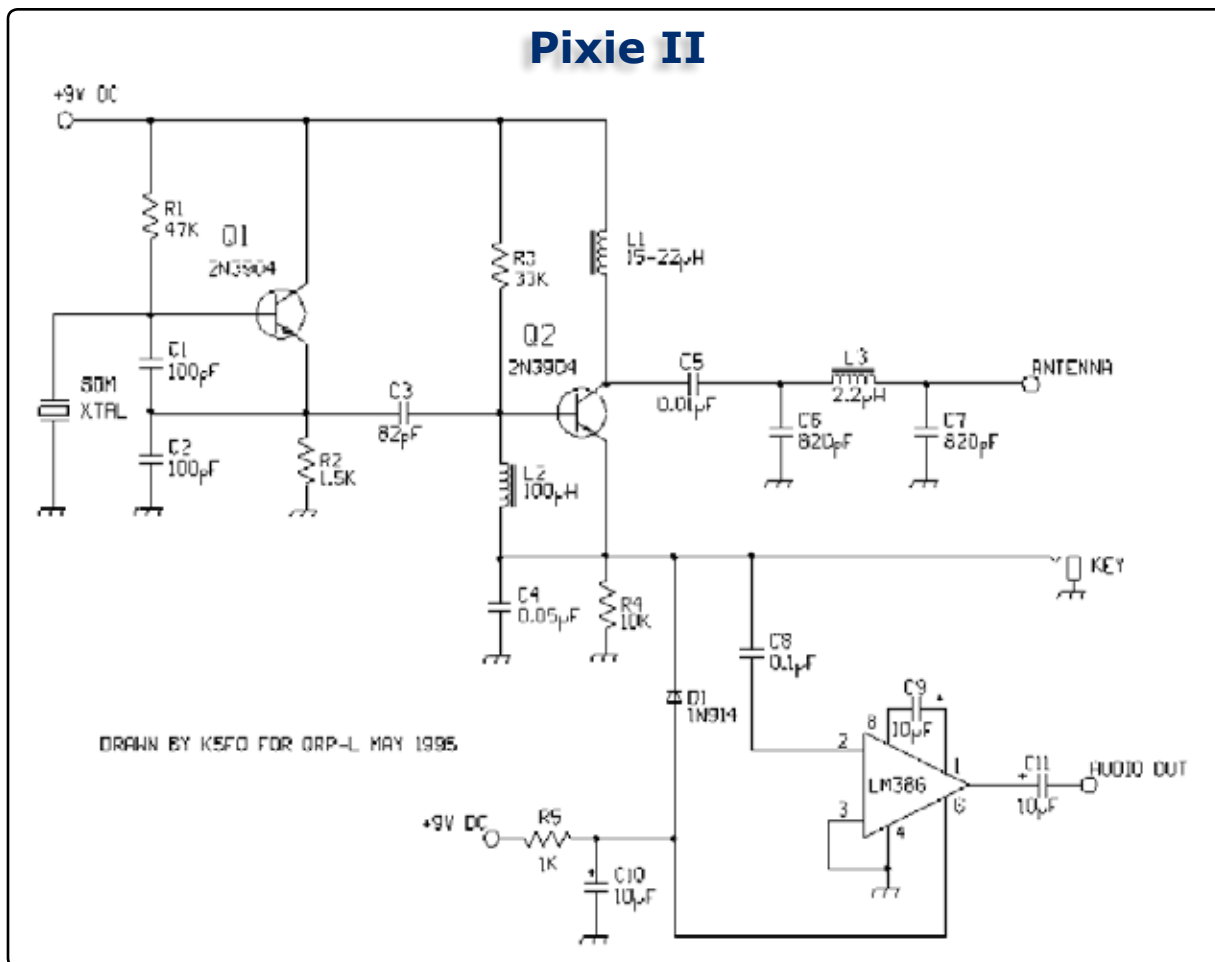

The Old Man and the Paperboy

Part I

Scott Laughlin, N7NET

Jack awoke with a start. Had he had missed the paperboy for the third morning this week? Gently, he laid back the blankets, so as not to disturb Millie, then groped for his trousers.

“What’s the matter?” she asked, her voice thick with sleep.

“Nothing. Go back to sleep,” he said, tugging on his trousers. After cinching his belt he grabbing his robe and slippers and headed for the door.

Fisherman’s Wharf lay not far away. He sometimes heard waterfront activity—the shriek of boat whistles and the slow rhythm of ships. But this morning all sounds were muffled except for the throaty moan of a distant foghorn. The corner streetlamp cast a grainy luster across the wet lawn.

“What on earth are you doing, Jack?”

Startled, he whirled about to find Millie on the porch, clutching her flowered robe tightly around her neck.

“I’m waiting on the paperboy,” he growled. “Go back to bed before you catch cold.”

The words hardly cleared his lips before the young man appeared on a speeding bicycle. Before Jack could draw a breath to summon the fellow, his newspaper sailed toward him and slid to a halt a few yards from where he stood.

“Hey! I want a word with you,” Jack shouted. He knew it was fruitless, this hollering business, because the speeding youngster had vanished as quickly as he’d appeared. Perhaps it was the curse of his old age that made hailing so futile. He stooped to retrieve his soggy Chronicle when the boy’s voice sounded.

“Mr. Wilcox, did you call me?”

Jack straightened and found himself looking into the face of a short, thin boy. “I did. What’s your name, young man?”

“Jimmy, sir.”

“Do you see what’s wrong here?”

“No sir,” answered Jimmy, his dark eyes searching the newspaper that Jack thrust toward him.

“Can’t you see that it’s soaking wet?”

“Well, everything’s wet this morning, sir. It’s the fog.”

“With a bit more force you might have sailed it onto my porch.”

“You want it on your porch?”

“I do.”

“I can do that.”

“Good. For every morning I find it on my porch I’ll add ten cents to your weekly fee.”

The boy smiled, but Jack could see that his mind was occupied elsewhere.

“May I ask you a question?”

“Like what?” growled Jack.

“Is that a tri-bander on that tower?”

Jack glanced toward the antenna, but it was not yet visible in the predawn light. “How’d you know about that?”

“I saw it when Mom was showing me my paper route.”

“And what do you know about radio antennas?”

“Not very much, only what I read in a magazine at the Laundromat. Do you have a radio room?”

“I do.”

“Can I see it?”

“Absolutely not.”

Jack had no tolerance for children. They were noisy and unruly. He knew he’d frightened the boy by

“Is that a tri-bander on that tower?”



Robert F. Heytow
Memorial Radio Club

www.k9ya.org
telegraph@k9ya.org

K9YA Telegraph

the way he'd grabbed his bike and fled, but it didn't matter. He didn't care. The little scamp had no business poking around and touching things in his radio room.

"You shouldn't have been so short with him," Millie complained, as Jack started for the porch.

"Well, maybe not, but I don't want a darn kid underfoot. He's a paperboy, for crying out loud. If I let him in one time he'll be back every day. I don't have time for such monkey business."

"I suppose not, your being retired an all," Millie said sarcastically. "How long has it been since you've turned on your radio? Six months? A year?"

He didn't answer, but held the door for her, instead. He watched Millie proceed toward the kitchen. By her stride it was obvious that this conversation was not finished.

He opened the Chronicle and scanned the editorial page before placing the paper near the furnace to dry. Then he moved to his recliner, leaned back, and closed his eyes. If only Millie had stayed in bed, he thought to himself. The sun was not yet up and the situation was already out of control.

"Breakfast."

Jack pulled himself from his recliner and headed into the kitchen. "One of the Chronicle editors thinks John Kennedy will be our next president," Jack said as he added milk the bowl of oatmeal she'd set before him. He knew she cared nothing for politics, so maybe a bit of Washington news would derail her crusade.

"How do you feel about that?" she asked as she dried her hands on her apron and joined him at the table. Raising her hand, she swept back a few strands of gray hair that had escaped from her bun and waited for his response.

"There's probably no difference between Kennedy and Nixon."

"But isn't Nixon a self-made man?" she asked.

"So they say, but that's only because he found the incriminating Pumpkin Papers that put Alger Hiss in prison. John Kennedy is the son of a man who made his fortune bootlegging Scotch whiskey during Prohibition. How can one be better than the other? Where's a Roosevelt when we need one?"

Millie's eyes glazed over and she nodded mechanically while she waited for Jack to run down.

"The paperboy is interested in amateur radio. Did you not notice that?" she asked after he fell silent.

"I did. But that's none of my affair. His father should help him, rather than me," he said while adding milk to his coffee.

"Jimmy, is that his name?"

"Yes, that's what he said."

"I know his mother. She's in our book club. She told me two weeks ago he was taking over this paper route. She's fearful that he isn't old enough. She's so protective of him, being a single mother and all."

"Divorced, I suppose," Jack mumbled between spoonfuls.

"Actually, her husband was killed in Korea shortly before Jimmy's birth."

Jack blinked, but he remained silent for a moment.

"That's unfortunate, Millie, but that has no bearing on me. I'm much too old to be of any use to a ten-year-old. Have you forgotten that I'm seventy-five? What on earth would we ever find in common?"

"Radio. It's the radio that you have in common; the same attraction that occurred between you and that old man you knew when you were a kid. What

was his name?"

"Wilson. Old Man Wilson."

"It radio that brought you two together, was it not?"

"Well, it was his wire antennas that first caught my attention. That old man taught me so much." Jack's voice trailed off as he focused on the past.

"How old were you?"

"Twelve."

"And Wilson?"

"I'm not sure. Eighty-something, I think."

"Eat your breakfast, Jack." ■



"Wilson. Old man Wilson."



Robert F. Heytow
Memorial Radio Club

www.k9ya.org
telegraph@k9ya.org

a network of radio amateurs to manage communications for this flight. In 1935 McMenemy monitored Earhart from her Lockheed Vega 5b on a 2,408-mile, Honolulu, Hawaii to Oakland, California flight. He used the antenna at broadcast station KECA in Los Angeles to hear her 50-watt Western Electric transmitter, thus he was familiar with the sound of her “radio voice” and operating style.



Amelia Earhart with her Vega in 1935 at Oakland.

In the United States the amateur radio operators selected to provide the flight’s communications were Guy Dennis, W6NNR; Karl Pierson, W6BGH; Frank Christman, W6ALJ; Charles Cheatham, W6CUU; Wally Gee, W6EGH; and John Pitts, W6CQK. Overseas stations included: VS1AB (Singapore), HS1PJ (Siam), VU2AX (India), ST2WF (Anglo-Egyptian Sudan), PY7AA (Brazil), PZ1AB (Netherlands Guiana), VP3BG (British Guiana), HP1A (Panama) and XE1G (Mexico).

Chicago Daily Tribune

March 21, 1937: Amelia Sails for U.S. After Crackup

Departing Luke Field, Honolulu, for Howland Island on the first leg of their voyage the Electra ground-looped causing severe damage to the aircraft. The crew, including Earhart, Manning and Noonan were shaken up but otherwise unhurt. The incident was attributed to “[the] plane... began swaying crazily as nearly three tons of fuel sloshed about in partly filled fuel tanks.” Other reports attributed the mishap to a blown tire, collapsed landing gear and “pilot error.” The aircraft was returned to the Lockheed facility in California for extensive repairs.

Earhart’s radio technician was Joseph Gurr (call sign unknown, but licensed since 1914), who with Guy Dennis, W6NNR, oversaw the installation and

modification of the Electra’s communications equipment while at Lockheed for repairs.

This crash ended amateurs’ official role in providing the flight’s communications; now the U.S. Navy and Coast Guard would assume that responsibility. In later years this change in plans helped fuel speculation Earhart was on a secret government mission scouting Japanese activity along her route over the Pacific.

Chicago Daily Tribune

May 30, 1937: Amelia Earhart to Fly World from West to East

The two-month long repair delay was time enough to necessitate changing the route to west to east due to seasonal changes in prevailing winds and weather patterns over the Atlantic Ocean and the African continent and now depart from Miami Municipal Airport, Miami, Florida. In addition, Capt. Manning was no longer available to accompany this flight so ending any direct link to amateur radio.

On July 2 Earhart left on the most hazardous leg of her journey—the 2,556-mile flight from Lae, New Guinea to Howland Island. Standing picket duty off Howland, a tiny coral island in the Phoenix Island group, and awaiting Earhart’s arrival was the Coast Guard cutter USCGC *Itasca*. Some 20 hours later the radio operator aboard *Itasca* received Earhart’s last radio transmission: *KHAQQ* to *Itasca*. *We are on the line of position one five seven dash three three seven. Will repeat this message on 6210 kilocycles. We are running north and south.*

Following Earhart’s disappearance the United States Coast Guard and Navy launched what would become, to that time, the world’s most extensive and expensive (estimated \$4,000,000) search operation. During this period several hams claimed they heard Earhart’s transmissions. Chief among these were Walter McMenemy and Karl Pierson (chief engineer, Patterson Radio Co.). McMenemy’s statements were given much weight because of his earlier role in this and the 1935 flight. His reports (he most likely heard *Itasca*’s transmissions and not Earhart’s) raised expectations for a time, but 12 days into the massive search it was abandoned.

Although few at the time could have known it the disastrous end of Amelia Earhart and Fred Noonan’s flight marked the birth of a legend and cast the parameters of an enduring mystery. ■

CONTINUED - AMELIA EARHART ON PAGE 7



Robert F. Heytow
Memorial Radio Club

www.k9ya.org
telegraph@k9ya.org

References

Atchison Daily Globe, July 3, 1937

Chicago Daily Tribune

CQ, April 1998

National Geographic Magazine, May 1935

Time, July 12, 1937

Amelia Earhart: The Mystery Solved, Elgen M. Long and Marie K. Long, Simon and Schuster, 2000, ISBN 074302171, 9780743202176

Amelia Earhart: The Sky's No Limit, Lori Van Pelt, MacMillan, 2005, ISBN 0765310619, 9780765310613

Amelia Earhart's Shoes: Is the Mystery Solved, Thomas F. King, Randall S. Jacobson, et.al., International Group for Historic Aircraft Recovery, Rowman Altamira, 2004, ISBN 0759101310, 97807591101319

The Aviation Annual, Reginald McIntosh Cleveland and Frederick P. Graham, Aviation Research Associates, Doubleday, Doran & Company, New York, 1944

Finding Amelia Earhart: The True Story of the Earhart Disappearance, Ric Gillespie, International Group for Historic Aircraft Recovery, Naval Institute Press, 2006, ISBN 1591143195 9781591143192

Lost Star: The Search for Amelia Earhart, Randall Brink, W.W. Norton & Company, 1995, ISBN 0393313115 9780393313116

The Sound of Wings, Mary S. Lovell, St. Martins Press, New York, 1989, ISBN 0-312-03431-8

Who's Who in Entertainment, Marquis Who's Who, 1988, ISBN 0837918502, 9780837918501

World Aircraft: Commercial 1935-1960, Enzo Angelucci and Paolo Matricardi, Rand McNally & Company, Chicago, 1979. ISBN: 0-528-88206-6



K9YA Pizza Bash - Fall 2009 Edition

Rod Newkirk, VA3ZBB/W9BRD

K9YA Telegraph contributing editor, Rod Newkirk, W9BRD/VA3ZBB, is currently in a medical facility undergoing rehabilitation following a mini-stroke. His wife, Betty Broome Newkirk, VE3ZBB, tells us Rod's spirits are high and his progress good.

Please join us in our prayers for Rod's rapid recovery and return to his favorite pursuits.

You may send your get well soon wishes to Rod via the K9YA Telegraph at: telegraph@k9ya.org



Call for Articles

Have a story to share? An experience to relate? Some gear to review? A technical tip to dispense? Feeling didactic or pedantic? Write it up, add a couple of appropriate photographs and send them off to the K9YA Telegraph. Hams worldwide will thank you, and so will we.

Here's the place to start:

http://www.k9ya.org/write_for_us.htm

Ham Quips

DICK SYLVAN, W9CBT

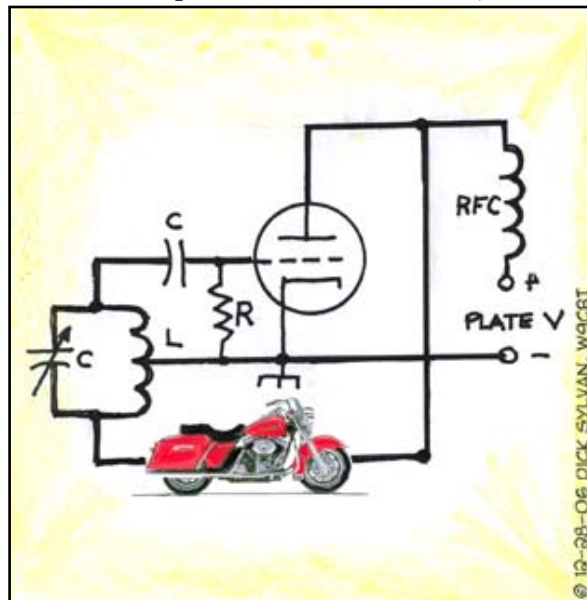

HARLEY OSCILLATOR CIRCUIT



Robert F. Heytow Memorial Radio Club

www.k9ya.org
telegraph@k9ya.org